

High Speed YARN & FIBER TENSION SENSOR

Model TP

4 Tension Ranges 0–50 g up to 0–500 g

Non-rotating ceramic pins make the Model TP sensor ideal for yarns and fibers running at speeds up to 6,000 m/min.

FEATURES

- Precision strain gauge sensing for highest accuracy and repeatability
- 0–1 V DC output, proportional to tension (0–10 V DC optional)
- Frequency response of 500 Hz
- Surface mount electronics provide long-term reliability
- 4mm diameter oxide ceramic pins are rated for filament speeds up to 6,000 m/min.
- Optional connecting cable

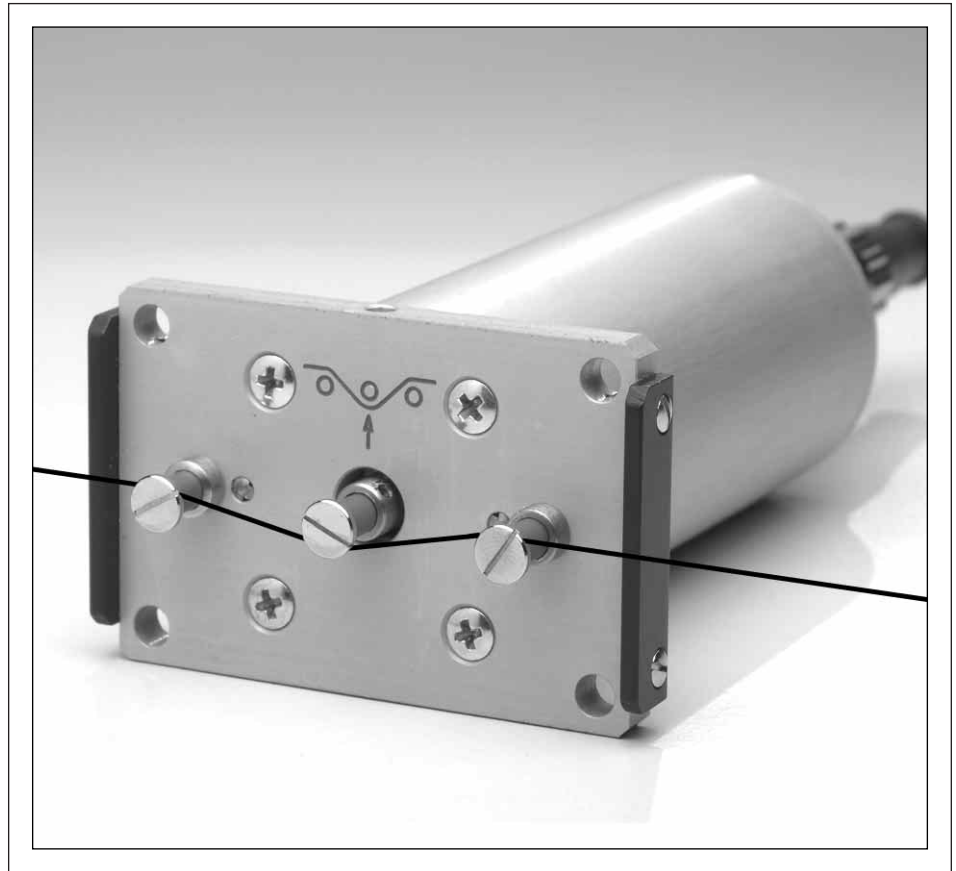

TENSION RANGES

Part Number	Measuring Range (grams)
TP-50	0–50
TP-100	0–100
TP-200	0–200
TP-500	0–500

Specifications

Accuracy	±1% FS (10–90% of range) ±3% FS (balance of range)	Middle Roller Deflection	0.5mm (maximum)
Regulated Sensor Excitation	12–15 V DC (–) @ 10 mA 12–15 V DC (+) @ 20 mA	Overload Rating	150% FS
Sensor Output	0–1 V DC (standard), 0–10 V DC (optional), proportional to tension	Housing Material	Aluminum
		Operating Temp.	40 to 105 °F (5–40 °C)
		Spacing of Outer Pins	40mm (c:c)
		Maximum Linear Speed	6,000 m/min

MODEL TP

TECHNICAL DATA & SPECIFICATIONS

Dimensions (50 g and 100 g)

All dimensions in mm

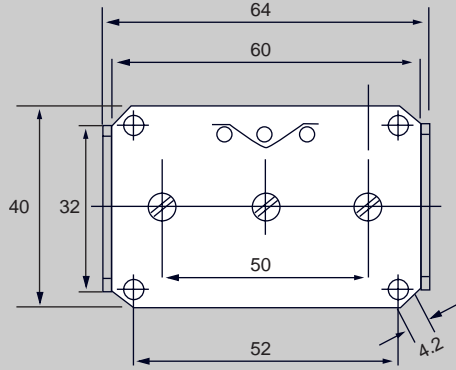

Dimensions (200 g and 500 g)

All dimensions in mm

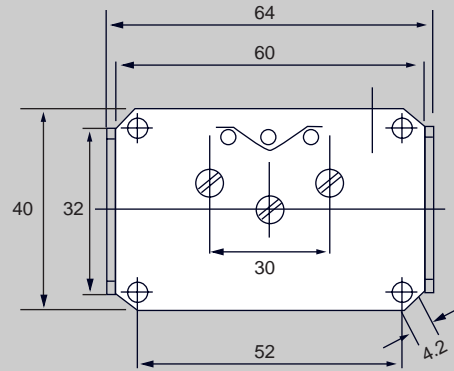

Output Plug

All dimensions in mm

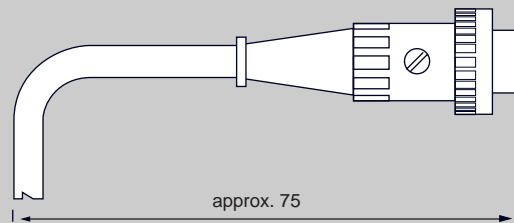

ELECTROMATIC

EQUIPMENT CO., INC.

600 Oakland Ave., Cedarhurst, NY 11516-U.S.A.
TEL 516-295-4300 • FAX 516-295-4399

For additional information
or to place an order
CALL TOLL FREE
1-800-645-4330

Visit our web site at <http://www.checkline.com>